

# Product Specification

## 概述 Outline



## 主要参数 Main Items

### 光学规格 Optical Specifications

	项目	Items	Description				Tolerances
1	焦距	Focal length	2.8mm				±5%
2	相对孔径	Aperture (D/f')	F1.8				±5%
3	成像靶面	Image Circle	1/2.7"				≥φ6.9mm
4	成像范围	Focus range	0.3m~INF				*
5	相对照度	VIG	≥42% (1/2.7")	≥50% (1/3")			±5%
6	TV 畸变	TV distortion	≤-19% (1/2.7")	≤-17% (1/3")			*
7	主光角	Chief ray angle	≤8° (1/2.7")	≤7° (1/3")			±5%
8	视场角	FOV (Focus on INF)	CMOS	D	H	V	±5%
			OV2710	140°	117°	63°	
			AR0237				
			IMX322	128°	108°	58°	
			IMX290	134°	113°	61°	
			OV4689	128°	108°	59°	
			IMX123	134°	102°	75°	

### 机械规格 Mechanical Specification

	项目	Items	Description		Tolerances
1	接口	Mount	M12X0.5		4h
2	光学构成	Lens structure	2G+3P		*
3	光学总长	Total track length	20.3mm(in air)		±0.1
4	机械后焦	Back focal length	5.3mm(in air)		±0.1
5	扭力范围	Torque range	/		±50
6	重量	Weight	3g		±1
7	操作方式	Operation	变倍 Zoom	固定 Fixed	*
			聚焦 Focus	固定 Fixed	
			光圈 Iris	固定 Fixed	

# Product Specification

## 5.3 结构图 Drawing

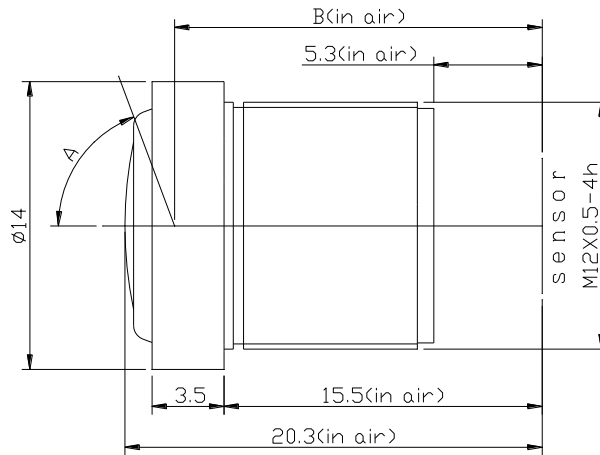

<b>Dimensions</b>	CMOS	OV2710	AR0237	IMX322	IMX290/291	IMX123	OV4689
	<b>A</b>	70°		64°	67°	67°	64°
	<b>B</b>	18.6		18.4	18.5	18.5	18.4
<b>Tolerance</b>	<b>Dimension</b>	<b>0-20</b>	<b>20-50</b>	<b>50-100</b>	<b>Unit</b>		
	<b>Tolerance</b>	±0.1	±0.2	±0.3	<b>mm</b>		

## 5.4 环境规格 Environment Specifications

	项目	Items	Description
1	工作温度	Working environment	-20°C~60°C; 10~90%RH
2	储存温度	Storage environment	-30°C~70°C; 10~90%RH
3	环保	HSF	RoHS

## 6 测试 Test

### 6.1 光学性能 Optical Performance

	项目	Items	Description				
1	分辨率	Resolution (line pair per mm)		Center	$\phi 4.5$	$\phi 6$	$\phi 8$
			2MP	/	/	/	/
			3MP	$\geq 200$	$\geq 125$	$\geq 100$	/
2	测试方法	Test Method	<ul style="list-style-type: none"> <li>0.6m of projection distance</li> <li>At max aperture</li> </ul>				
			5MP	/	/	/	/

### 6.2 外观测试 Appearance Performance

	项目	Items	Description
1	外观	Appearance	<ul style="list-style-type: none"> <li>Dust standard: 60-20</li> <li>Scratches: Width&lt;60um, Length&lt;D/2</li> <li>Spot: <math>\phi &lt; 200\text{um}</math>, 100~200um<math>\leq 3</math></li> </ul>
2	测试方法	Test Method	<ul style="list-style-type: none"> <li>Visual inspection</li> </ul>

## Product Specification

### 可靠性测试 Reliability Test

#### 测试方法 Test Method

	项目	Test Item	Specification						
1	高低温测试 (储存)	Temperature test (non-operating)	<ul style="list-style-type: none"> <li>70 °C, normal humidity, 72hours</li> <li>-30 °C, normal humidity, 72hours</li> </ul>						
2	温度循环 (储存)	Temperature cycle test (non-operating)	<table border="1" style="margin-left: 20px;"> <tr> <td>2hours</td> <td>2hours</td> <td>2hours</td> </tr> <tr> <td>-30 °C</td> <td>70 °C</td> <td>-30 °C</td> </tr> </table> <ul style="list-style-type: none"> <li>Stay 2 hours each phase, 10 cycles totally</li> </ul>	2hours	2hours	2hours	-30 °C	70 °C	-30 °C
2hours	2hours	2hours							
-30 °C	70 °C	-30 °C							
3	温度循环 (工作)	Temperature cycle test (Operating with camera)	<table border="1" style="margin-left: 20px;"> <tr> <td>2hours</td> <td>2hours</td> <td>2hours</td> </tr> <tr> <td>-20 °C</td> <td>60 °C</td> <td>-20 °C</td> </tr> </table> <ul style="list-style-type: none"> <li>Stay 2 hours each phase, 10 cycles totally</li> </ul>	2hours	2hours	2hours	-20 °C	60 °C	-20 °C
2hours	2hours	2hours							
-20 °C	60 °C	-20 °C							
4	温度循环 (带包装)	Temperature Cycle Test (With package)	<table border="1" style="margin-left: 20px;"> <tr> <td>2hours</td> <td>2hours</td> <td>2hours</td> </tr> <tr> <td>-30 °C</td> <td>70 °C</td> <td>-30 °C</td> </tr> </table> <ul style="list-style-type: none"> <li>Stay 2 hours each phase, 10 cycles totally</li> </ul>	2hours	2hours	2hours	-30 °C	70 °C	-30 °C
2hours	2hours	2hours							
-30 °C	70 °C	-30 °C							
5	冷热冲击 (储存)	Thermal shock test (non-operating)	<table border="1" style="margin-left: 20px;"> <tr> <td>0.5 hours</td> <td>0.5hours</td> <td>0.5hours</td> </tr> <tr> <td>-30 °C</td> <td>70 °C</td> <td>-30 °C</td> </tr> </table> <ul style="list-style-type: none"> <li>Stay 0.5 hours each phase, 10 cycles totally</li> </ul>	0.5 hours	0.5hours	0.5hours	-30 °C	70 °C	-30 °C
0.5 hours	0.5hours	0.5hours							
-30 °C	70 °C	-30 °C							
6	振动测试 (储存)	Vibration test (non-operating)	<ul style="list-style-type: none"> <li>1.5G, Sine- Wave 10 ~ 450 Hz for 1.0 octave/min; X/Y direction for 0.5 hour; Z direction for 1 hour</li> </ul>						
7	振动测试 (带包装)	Vibration test (With package)	<ul style="list-style-type: none"> <li>1.5G, Sine- Wave 10 ~ 450 Hz for 1.0 octave/min; X/Y direction for 0.5 hour; Z direction for 1 hour</li> </ul>						
8	跌落测试 (带包装)	Drop test (With package)	<ul style="list-style-type: none"> <li>Drop height: 100 cm</li> <li>Drop position: 1 corner, 3 edges, 6 planes</li> </ul>						

\*All tests are doing under the standard parameter settings of testing machine. Lens will be judged as qualified when the motor can be driven normally without jump, idling, stalling and other anomalies. Testing environment: 27 ±2 °C; 45% ±5% RH

