

4 概述 Outline



5 主要参数 Main Items

5.1 光学规格 Optical Specifications

	项目	Items	Description				Tolerances
1	焦距	Focal length	8mm				±5%
2	相对孔径	Aperture (D/f')	F1.6				±5%
3	成像靶面	Image Circle	1/2.5"				>7.4mm
4	成像范围	Focus range	0.3m~INF				*
5	TV 畸变	TV distortion	-3.8%				*
6	主光角	Chief ray angle	<9°				±5%
7	视场角	FOV (Focus on INF)	CMOS	D	H	V	±5%
			AR0230	45°	40°	23°	
			IMX290	44°	38°	22°	
			OV4689 IMX322	39°	37°	18°	
			AR0130 IMX225	41	33°	25°	

5.2 机械规格 Mechanical Specification

	项目	Items	Description		Tolerances
1	接口	Mount	M12X0.5		*
2	光学构成	Lens structure	5 groups, 7 elements		*
3	光学总长	Total track length	23.5mm(in air)		±0.1
4	法兰后焦	Flange focal length	/		*
5	机械后焦	Back focal length	6.6mm		±0.1
6	扭力范围	Torque range	/		*
7	重量	Weight	6g		±10%
8	操作方式	Operation	变倍 Zoom	固定 Fixed	*
			聚焦 Focus	固定 Fixed	
			光圈 Iris	固定 Fixed	

结构图 Drawing

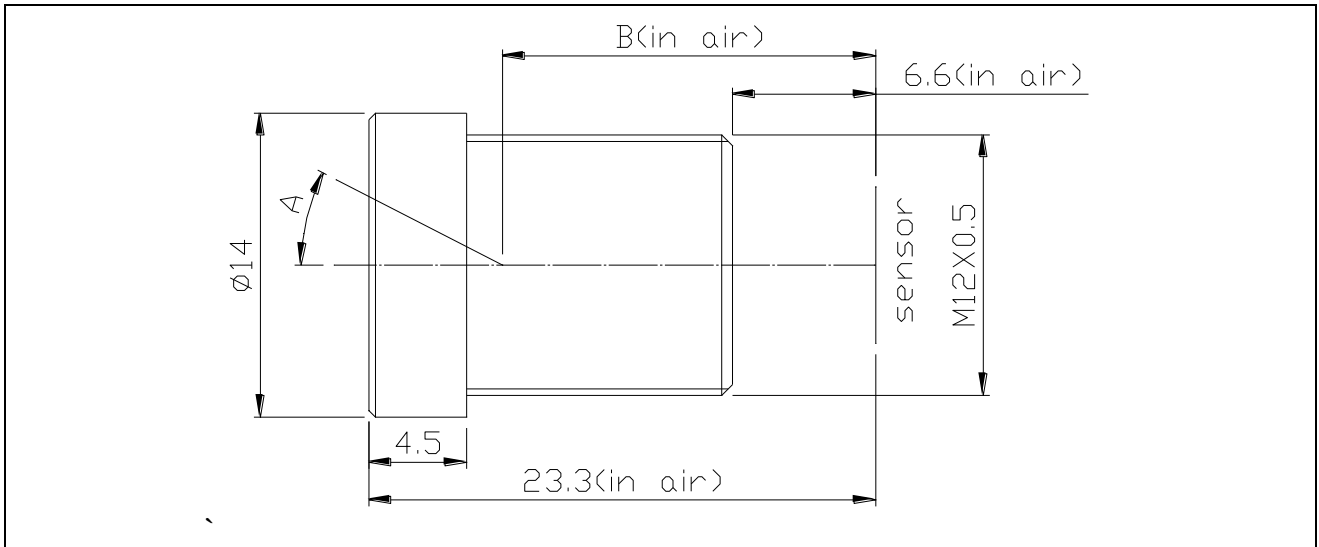

Dimensions	芯片型号	AR0130	AR0230	SONY225	SONY290/291	OV4689
	A	22.8°	24.6°	22.8°	23.7°	22.2°
	B	16.3	16.7	16.3	16.5	16.1
Tolerances	Dimensions	0-25	25-50	50-100	100-150	Unit
	Tolerances	±0.1	±0.2	±0.3	±0.4	mm

环境规格 Environment Specifications

	项目	Items	Description
1	工作温度	Working environment	-20°C~60°C; 10~90%RH
2	储存温度	Storage environment	-30°C~70°C; 10~90%RH
3	环保	HSF	RoHS

测试 Test

光学性能 Optical Performance

	项目	Items	Description				
1	分辨率	Resolution (line pair per mm)	Center	φ 4.5	φ 6	φ 8	
			3MP	≥160	≥125	≥100	/
			5MP	≥200	≥160	≥125	/
2	测试方法	Test Method	<ul style="list-style-type: none"> 0.6m of projection distance At max aperture 				

外观测试 Appearance Performance

	项目	Items	Description
1	外观	Appearance	<ul style="list-style-type: none"> Dust standard: 60-20 Scratches: Width<60um, Length<D/2 Spot: φ<200um, 100~200um≤3
2	测试方法	Test Method	<ul style="list-style-type: none"> Visual inspection

可靠性测试 Reliability Test

测试方法 Test Method

	项目	Test Item	Specification						
1	高低温测试 (储存)	Temperature test (non-operating)	<ul style="list-style-type: none"> 70 °C, normal humidity, 72hours -30 °C, normal humidity, 72hours 						
2	温度循环 (储存)	Temperature cycle test (non-operating)	<table border="1"> <tr> <td>2hours</td> <td>2hours</td> <td>2hours</td> </tr> <tr> <td>-30 °C</td> <td>70 °C</td> <td>-30 °C</td> </tr> </table> <ul style="list-style-type: none"> Stay 2 hours each phase, 10 cycles totally 	2hours	2hours	2hours	-30 °C	70 °C	-30 °C
2hours	2hours	2hours							
-30 °C	70 °C	-30 °C							
3	温度循环 (工作)	Temperature cycle test (Operating with camera)	<table border="1"> <tr> <td>2hours</td> <td>2hours</td> <td>2hours</td> </tr> <tr> <td>-20 °C</td> <td>60 °C</td> <td>-20 °C</td> </tr> </table> <ul style="list-style-type: none"> Stay 2 hours each phase, 10 cycles totally 	2hours	2hours	2hours	-20 °C	60 °C	-20 °C
2hours	2hours	2hours							
-20 °C	60 °C	-20 °C							
4	温度循环 (带包装)	Temperature Cycle Test (With package)	<table border="1"> <tr> <td>2hours</td> <td>2hours</td> <td>2hours</td> </tr> <tr> <td>-30 °C</td> <td>70 °C</td> <td>-30 °C</td> </tr> </table> <ul style="list-style-type: none"> Stay 2 hours each phase, 10 cycles totally 	2hours	2hours	2hours	-30 °C	70 °C	-30 °C
2hours	2hours	2hours							
-30 °C	70 °C	-30 °C							
5	冷热冲击 (储存)	Thermal shock test (non-operating)	<table border="1"> <tr> <td>0.5 hours</td> <td>0.5hours</td> <td>0.5hours</td> </tr> <tr> <td>-30 °C</td> <td>70 °C</td> <td>-30 °C</td> </tr> </table> <ul style="list-style-type: none"> Stay 0.5 hours each phase, 10 cycles totally 	0.5 hours	0.5hours	0.5hours	-30 °C	70 °C	-30 °C
0.5 hours	0.5hours	0.5hours							
-30 °C	70 °C	-30 °C							
6	振动测试 (储存)	Vibration test (non-operating)	<ul style="list-style-type: none"> 1.5G, Sine- Wave 10 ~ 450 Hz for 1.0 octave/min; X/Y direction for 0.5 hour; Z direction for 1 hour 						
7	振动测试 (带包装)	Vibration test (With package)	<ul style="list-style-type: none"> 1.5G, Sine- Wave 10 ~ 450 Hz for 1.0 octave/min; X/Y direction for 0.5 hour; Z direction for 1 hour 						
8	跌落测试 (带包装)	Drop test (With package)	<ul style="list-style-type: none"> Drop height: 100 cm Drop position: 1 corner, 3 edges, 6 planes 						

*All tests are doing under the standard parameter settings of testing machine. Lens will be judged as qualified when the motor can be driven normally without jump, idling, stalling and other anomalies. Testing environment: 27±2 °C; 45% ±5%RH

